

## Silicon Z-Diodes

### Features

- Glass passivated junction
- High reliability
- Voltage range 10V to 270V
- Fits onto 5 mm SMD footpads
- Wave and reflow solderable

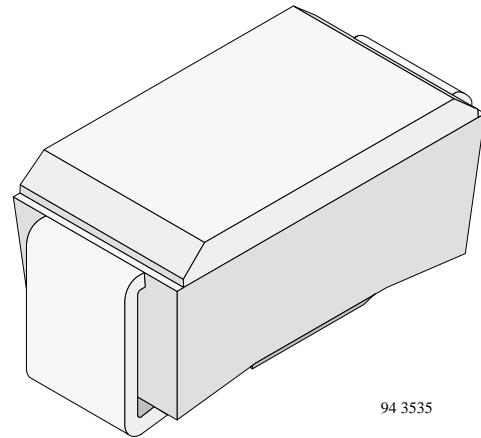

94 3535

### Applications

Voltage stabilization

### Absolute Maximum Ratings

$T_j = 25^\circ\text{C}$

Parameter	Test Conditions	Type	Symbol	Value	Unit
Power dissipation	$R_{thJA} < 25\text{K/W}$ , $T_{amb} = 100^\circ\text{C}$		$P_V$	3	W
	$R_{thJA} < 100\text{K/W}$ , $T_{amb} = 50^\circ\text{C}$		$P_V$	1.25	W
Non repetitive peak surge power dissipation	$t_p = 100\mu\text{s}$ sq.pulse, $T_j = 25^\circ\text{C}$ prior to surge		$P_{ZSM}$	600	W
Junction temperature			$T_j$	175	$^\circ\text{C}$
Storage temperature range			$T_{stg}$	-65...+175	$^\circ\text{C}$

### Maximum Thermal Resistance

$T_j = 25^\circ\text{C}$

Parameter	Test Conditions	Symbol	Value	Unit
Junction lead		$R_{thJL}$	25	K/W
Junction ambient	mounted on epoxy-glass hard issue, Fig. 1a	$R_{thJA}$	150	K/W
	mounted on epoxy-glass hard issue, Fig. 1b	$R_{thJA}$	125	K/W
	mounted on Al-oxid-ceramic ( $\text{Al}_2\text{O}_3$ ), Fig. 1b	$R_{thJA}$	100	K/W

### Characteristics

$T_j = 25^\circ\text{C}$

Parameter	Test Conditions	Type	Symbol	Min	Typ	Max	Unit
Forward voltage	$I_F = 0.5\text{A}$		$V_F$			1.2	V

Type BZG03C...	V <sub>Z</sub> V			r <sub>zj</sub> and Ω		TK <sub>VZ</sub> at %/K		I <sub>Z</sub> mA	I <sub>R</sub> μA	at V <sub>R</sub> V
	Min.	Typ.	Max.	Typ.	Max.	Typ.	Max.		Max.	
10	9.4	10	10.6	2	4	0.05	0.09	50	10	7.5
11	10.4	11	11.6	4	7	0.05	0.10	50	4	8.2
12	11.4	12	12.7	4	7	0.05	0.10	50	3	9.1
13	12.4	13	14.1	5	10	0.05	0.10	50	2	10
15	13.8	15	15.6	5	10	0.05	0.10	50	1	11
16	15.3	16	17.1	6	15	0.06	0.11	25	1	12
18	16.8	18	19.1	6	15	0.06	0.11	25	1	13
20	18.8	20	21.2	6	15	0.06	0.11	25	1	15
22	20.8	22	23.3	6	15	0.06	0.11	25	1	16
24	22.8	24	25.6	7	15	0.06	0.11	25	1	18
27	25.1	27	28.9	7	15	0.06	0.11	25	1	20
30	28	30	32	8	15	0.06	0.11	25	1	22
33	31	33	35	8	15	0.06	0.11	25	1	24
36	34	36	38	21	40	0.06	0.11	10	1	27
39	37	39	41	21	40	0.06	0.11	10	1	30
43	40	43	46	24	45	0.07	0.12	10	1	33
47	44	47	50	24	45	0.07	0.12	10	1	36
51	48	51	54	25	60	0.07	0.12	10	1	39
56	52	56	60	25	60	0.07	0.12	10	1	43
62	58	62	66	25	80	0.08	0.13	10	1	47
68	64	68	72	25	80	0.08	0.13	10	1	51
75	70	75	79	30	100	0.08	0.13	10	1	56
82	77	82	87	30	100	0.08	0.13	10	1	62
91	85	91	96	60	200	0.09	0.13	5	1	68
100	94	100	106	60	200	0.09	0.13	5	1	75
110	104	110	116	80	250	0.09	0.13	5	1	82
120	114	120	127	80	250	0.09	0.13	5	1	91
130	124	130	141	110	300	0.09	0.13	5	1	100
150	138	150	156	130	300	0.09	0.13	5	1	110
160	158	160	171	150	350	0.09	0.13	5	1	120
180	168	180	191	180	400	0.09	0.13	5	1	130
200	188	200	212	200	500	0.09	0.13	5	1	150
220	208	220	233	350	750	0.09	0.13	2	1	160
240	228	240	256	400	850	0.09	0.13	2	1	180
270	251	270	289	450	1000	0.09	0.13	2	1	200

## Typical Characteristics ( $T_j = 25^\circ\text{C}$ unless otherwise specified)

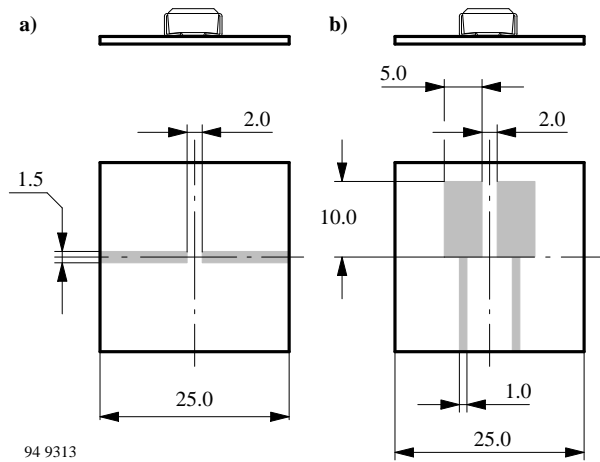

Figure 1 : Boards for  $R_{thJA}$  definition (copper overlay  $35\mu$ )

94 9313

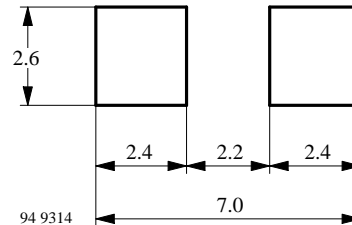

Figure 2 : Recommended foot pads

94 9314

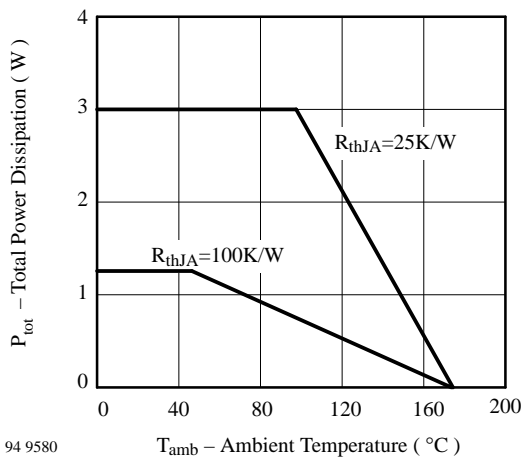

Figure 3 : Total Power Dissipation vs. Ambient Temperature

94 9580

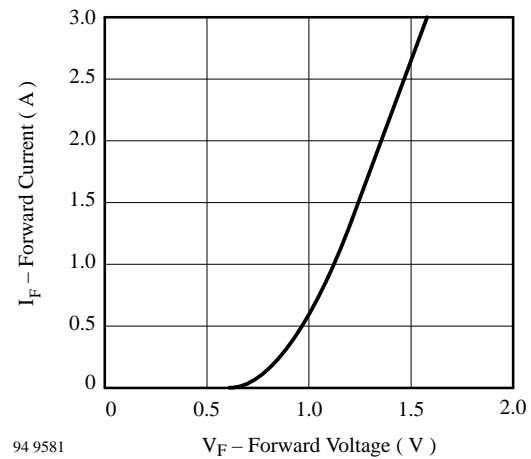

Figure 4 : Forward Current vs. Forward Voltage

94 9581

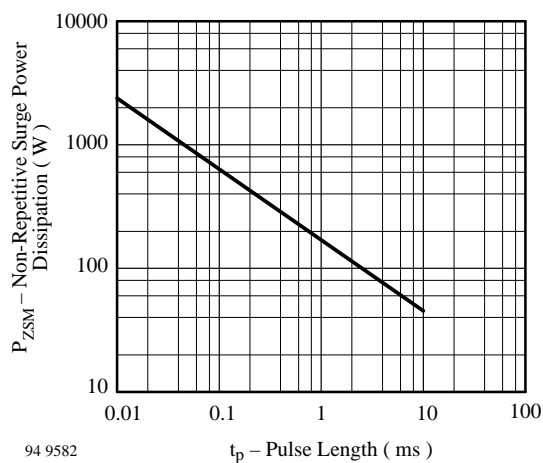

Figure 5 : Non Repetitive Surge Power Dissipation vs. Pulse Length

94 9582

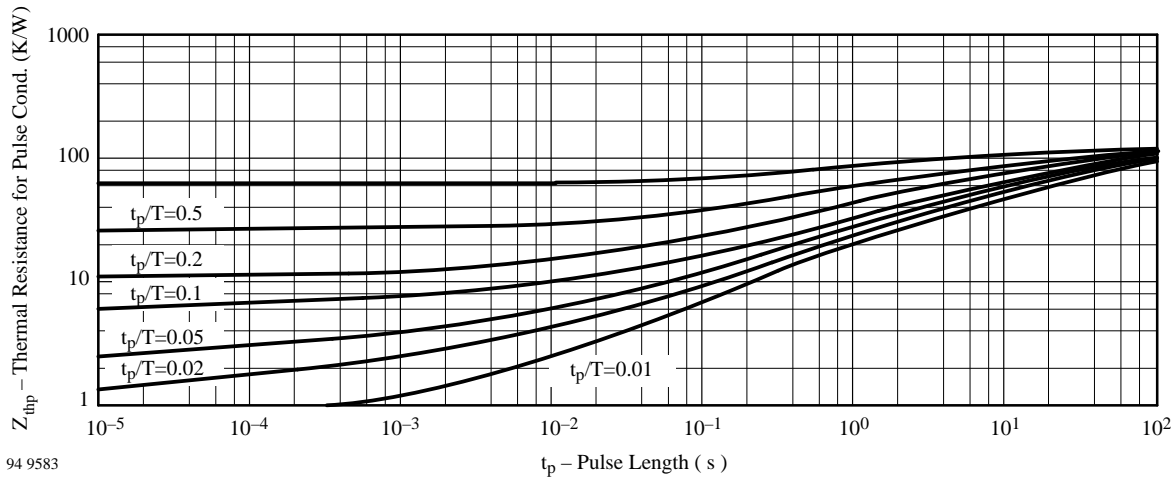
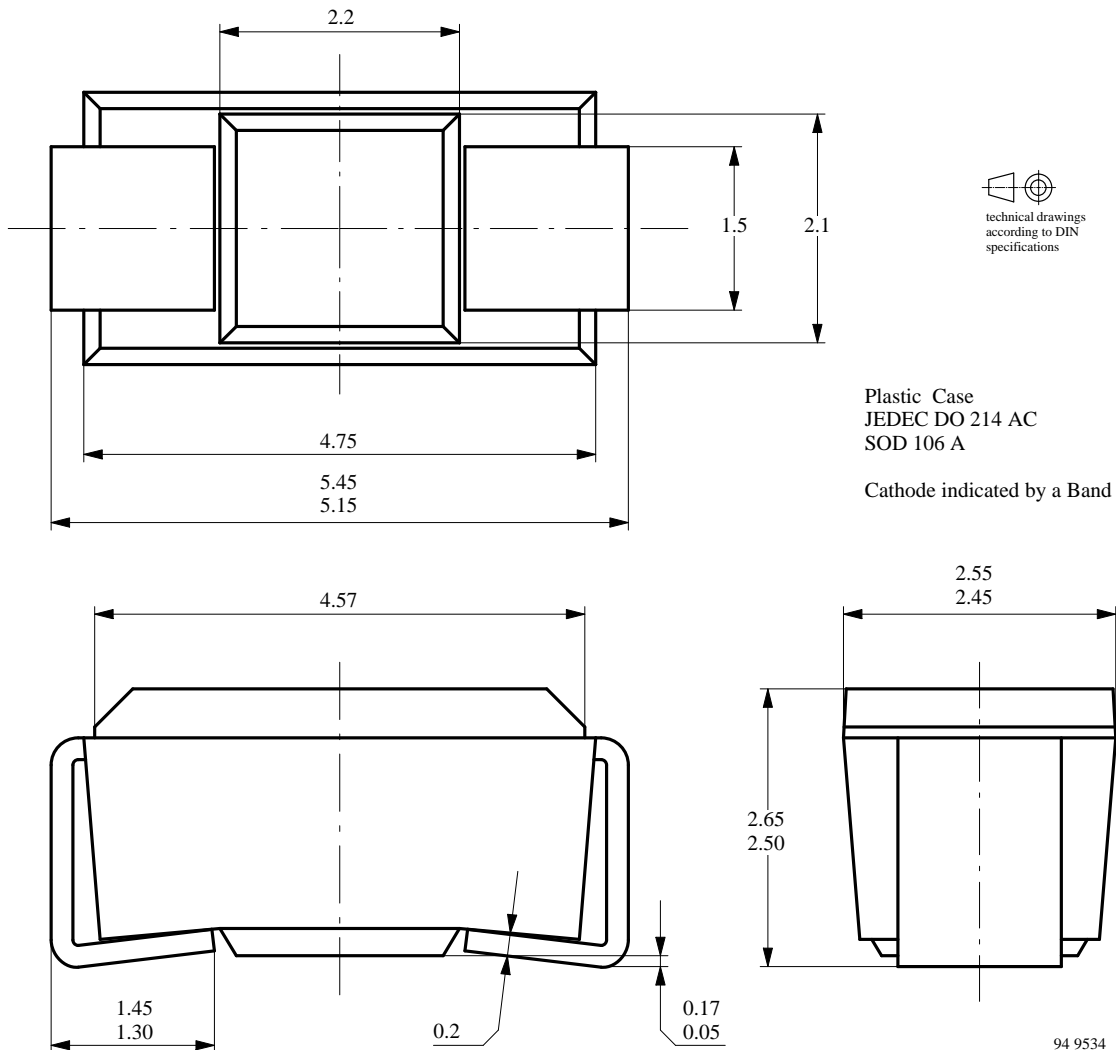

Figure 6 : Thermal Response

## Dimensions in mm



94 9534

---

## OZONE DEPLETING SUBSTANCES POLICY STATEMENT

It is the policy of **TEMIC TELEFUNKEN microelectronic GmbH** to

1. Meet all present and future national and international statutory requirements and
2. Regularly and continuously improve the performance of our products, processes, distribution and operating systems with respect to their impact on the health and safety of our employees and the public, as well as their impact on the environment.

Of particular concern is the control or elimination of releases into the atmosphere of those substances which are known as ozone depleting substances (ODSs).

The Montreal Protocol (1987) and its London Amendments (1990) will soon severely restrict the use of ODSs and forbid their use within the next ten years. Various national and international initiatives are pressing for an earlier ban on these substances.

**TEMIC TELEFUNKEN microelectronic GmbH** semiconductor division has been able to use its policy of continuous improvements to eliminate the use of any ODSs listed in the following documents.

1. Annex A, B and list of transitional substances of the Montreal Protocol and the London Amendments respectively
2. Class I and II ozone depleting substances in the Clean Air Act Amendments of 1990 by the Environmental Protection Agency (EPA) in the USA and
3. Council Decision 88/540/EEC and 91/690/EEC Annex A, B and C (transitional substances) respectively.

**TEMIC** can certify that our semiconductors are not manufactured with and do not contain ozone depleting substances.

**We reserve the right to make changes to improve technical design without further notice.**

Parameters can vary in different applications. All operating parameters must be validated for each customer application by the customer. Should the buyer use TEMIC products for any unintended or unauthorized application, the buyer shall indemnify TEMIC against all claims, costs, damages, and expenses, arising out of, directly or indirectly, any claim of personal damage, injury or death associated with such unintended or unauthorized use.

TEMIC TELEFUNKEN microelectronic GmbH, P.O.B. 3535, D-74025 Heilbronn, Germany  
Telephone: 49 (0)7131 67 2831, Fax Number: 49 (0)7131 67 2423